

MiniVert Model 1200

MiniVert is a storage and retrieval device that efficiently stores items using a minimum amount of floor space.

MiniVert brings stored items to the operator, eliminating hunting and searching through rows of conventional shelving.

Benefits:

- Pick-to-light and barcode verification improve dispensing accuracy
- Enhanced security through password access and full metal enclosure
- Designed to fit through standard doorway for plug-and-play installation
- 30% to 50% floor space savings

Features:

- Series of triple level carriers rotating in a vertical closed loop track bring product to operator, reducing fatigue and increasing productivity
- Operator controls located conveniently near access door
- Safety devices include touch bar and infrared photo eye pinch point protection
- Host computer interface provides for direct integration with any software
- Enclosed external drive and controller for ease of serviceability
- Emergency crank system provides safe access to product

Spec Sheet



Performance:

- Unit capacity: 3,300 pounds, gross load
- Carrier capacity: 330 pounds
- Scissor arm capacity: 410 pounds per pair
- Carrier speed: 25 feet per minute
- Maximum imbalance: 300 pounds
- Stopping accuracy: $\pm 5/16$ inch
- Duty cycle: 100% continuous duty

Power requirements:

- Voltage: 115 V AC to 120 V AC, 60 Hz, single-phase
- Current: 15 A

Specifications

Safety systems:

- EMERGENCY STOP button
- Touch bars
- Product protect photo eyes
- Access panel interlock switches
- System status and safety condition screens on built-in control panel

Controller:

- ETL listed
- FCC listed
- 128 x 64 graphics display
- Built-in Smart Bar control
- RS-232 serial interface
- Compatible with software
- Field replaceable to minimize downtime

Physical characteristic:

- Depth: 34 inches
- Width: 66 inches
- Height: 75.5 inches
- Shipping weight: 1,500 pounds
- Installation clearances: 12 inches each side, 1 inch at back

Environmental considerations:

- Temperature range: 40° F to 120° F
- Humidity: 5-95% relative humidity, non-condensing

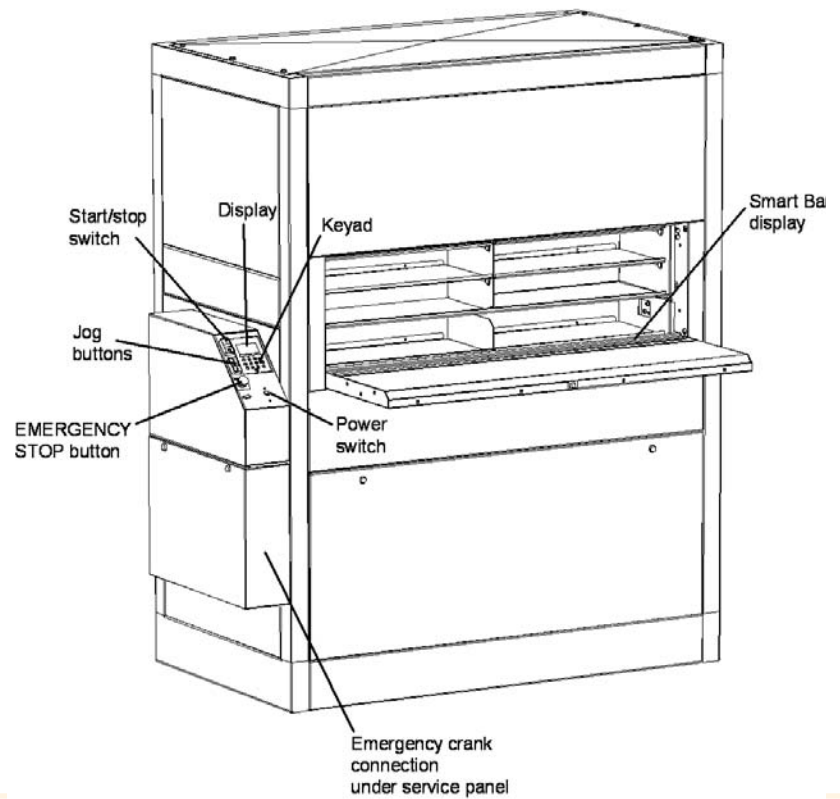

Load chain:

- Number 80 roller chain
- Static safety factor of 20:1

Bearings:

- Sealed, heavy-duty design
- No maintenance required

www.whitesystems.com

White Systems, Inc.
30 Boright Avenue
Kenilworth, NJ 07033

Main office: (800) 275-1442
Fax: (908) 272-5920
Email: info@whitesystems.com

Customer Service and Support: (800) 571-8822
Fax: (908) 272-2561



SYSTEMS
INNOVATING STORAGE & RETRIEVAL